

DOT PEEN MARKING MACHINE i-speed



ONE OF THE FASTEST
ON THE MARKET



- + Continuous oscillating marking technology allows an extremely fast permanent marking
- + Marking speed up to 10 characters per second
- + Significant productivity gains

+ ROBUST AND RELIABLE

- Reduced maintenance
- Design for intensive use in industrial environments

+ POWERFUL

- Accurate guides
- Marking uniformity over the entire marking area
- Marking on all types of material and difficult surface conditions
- 3 mm tolerance of stylus / part variation distance

ULTRA COMPACT



- + Small dimensions : 218 x 107 x 62 mm
- + Easy integration: 4 mounting orientations
- + Marking window: 50 x 20 mm

IN SHORT



Continuous oscillating marking technology is a variant of dot peen which consists in oscillating the stylus during its movement to obtain *continuous marking which is more aesthetic* than electromagnetic dot peen.

APPLICATIONS



DOT PEEN MARKING EXAMPLES *visually superior marking*



TECHNICAL & MECHANICAL FEATURES

e10 i-speed	
Marking window	50 x 20 mm - 1.9 x 0.8 in
External dimensions	218 x 107 x 62 mm - 8.6 x 4.2 x 2.4 in
Weight	1.7 kg - 2.2 lbs
Stylus	Tungsten carbide 60 mm - 2.4 in
Power	compressed air - 6 bar
Controller cable length	5 or 10 m (16.4 or 32.8 ft)

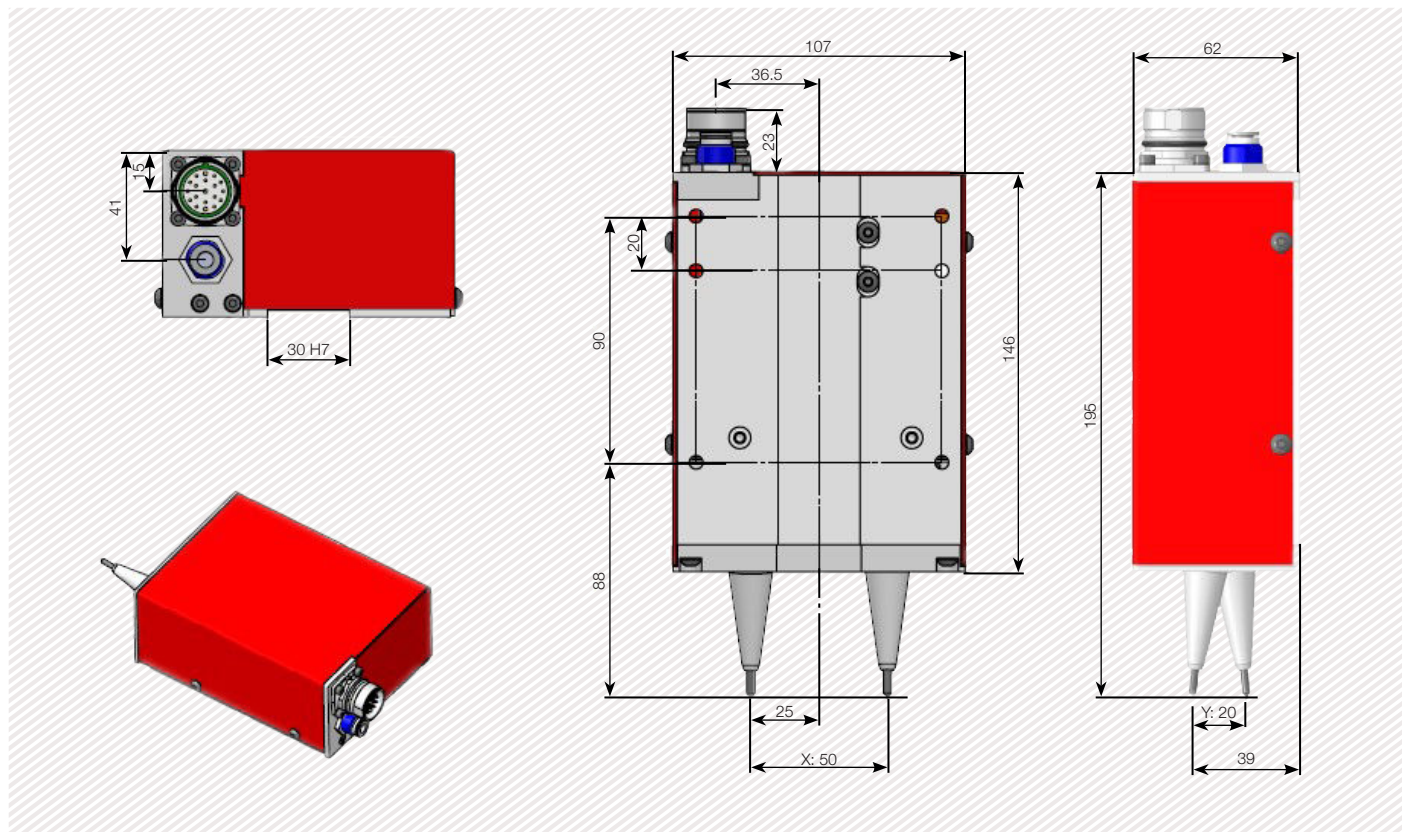

OPTIONS



Z axis 50 to 250 mm



DIN rail kit for e10R controller



Standard or very fast stylus



Start & Stop Button Box

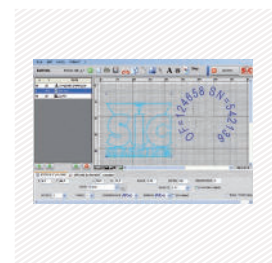

PC software

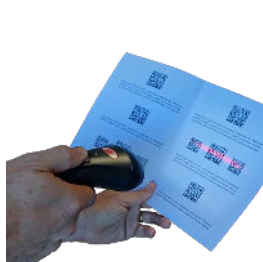

1D / 2D reader (wireless)



Barcode reader (wireless)



Maintenance kit

Please consult us if a specific configuration is not published in the table attached.

SIC Marking designs customised and turnkey solutions for all industrial sectors. Our design offices produce machines in compliance with your specifications and your industrial standards.

E10 CONTROL UNIT

The e10 controller

- Colour screen
- USB Port on front panel (easy access): to easily upload / download your marking files
- Fully programmable
- Standalone (no PC needed)
- Membrane protected industrial Keyboard
- IP40 waterproof box (no opening or fan)



+ Colour screen

+ USB Port on front panel



+ Multiple connectivities



+ PC software and utilities



Technical & electronic features

e10 Controller		Communication	
Dimensions	322 x 380 x 112 mm - 13.7 x 15 x 4.4 in	Communication ports	RS232, RS422, USB, RS485 Profibus, TCP/IP, Ethernet/IP
Weight	5 kg - 11lbs	Inputs-outputs	8/8
LCD screen resolution	480 x 272 pixels	External keyboard input	USB
Keyboard	Qwerty integrated, protected by membrane	PC software	Creation of marking files, transfer controller / PC or USB key
Power	300 Watt	Optional communication cards:	
Power supply	Single phase, 85 to 260 VAC, 50 to 60 Hz	Ethernet TCP	
Controlled axes	2 (optional 3rd / 4th axis card)		 
Operating temperature	From 5 to 40°C		

PC UTILITIES

File editor

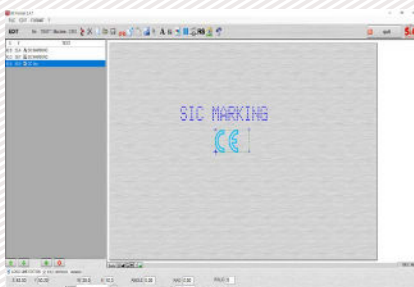

+ Creation or modification of files on PC.

Creation of logos

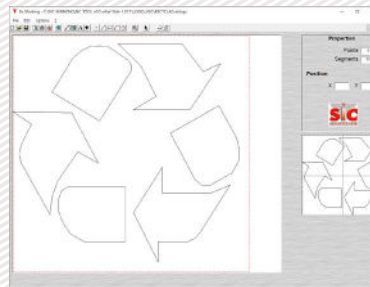

+ Creation of vector and matrix logos.

File manager

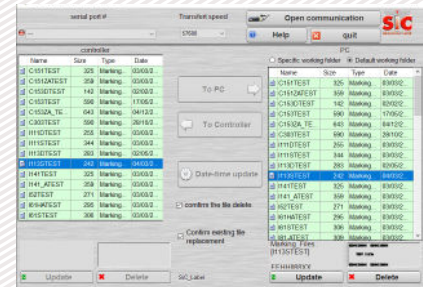

+ Backup and file transfer utility.

E10 RANGE SOFTWARE

Software features

Text function	Incrementation, date codes
Logos	Download from a PC or USB key
Fonts	Arial, Comic, Comic_B, Courier, OCR, OCR_BOLD, OCRA
Style	Angular, Radial, Inverse, and Mirror
Character Size	From 0,1 mm to 99 mm (limited following marking window)
Password	2 security levels
History function	Exportable Excel file
Help with maintenance	Auto diagnosis
Available languages	17



Graphic view

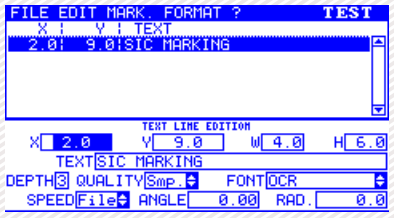

Edit menu

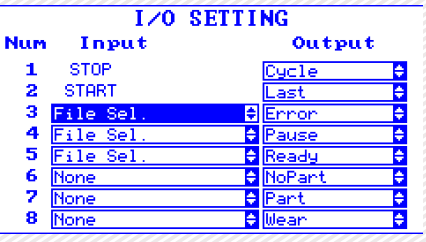

Num	Input	Output
1	STOP	Cycle
2	START	Last
3	File Sel.	Error
4	File Sel.	Pause
5	File Sel.	Ready
6	None	NoPart
7	None	Part
8	None	Wear

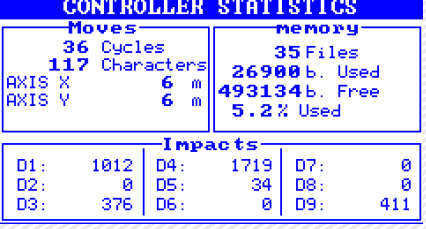

Moves		memory	
36	Cycles	35	Files
117	Characters	26900	b. Used
AXIS X	6 m	493134	b. Free
AXIS Y	6 m	5.2%	Used

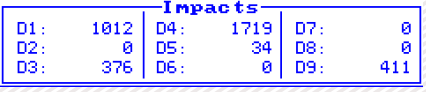

Impacts					
D1:	1012	D4:	1719	D7:	0
D2:	0	D5:	34	D8:	0
D3:	376	D6:	0	D9:	411

PC software for directly controlling the marking machine.

Available functions:

- Editing of marking files
- Input / output management
- History function and anti duplicates
- Variable text data

OPTIONAL WINSIC SOFTWARE

WINSIC is a PC software for direct control of the marking machine.

+ Database Management (Excel, Access, txt)

+ Insertion of background images

+ Built-in logo design utility

